

## Installation Instructions for CL400 ADA Magnetic Bi-Parting Passage (Magnetic Latching) Handles

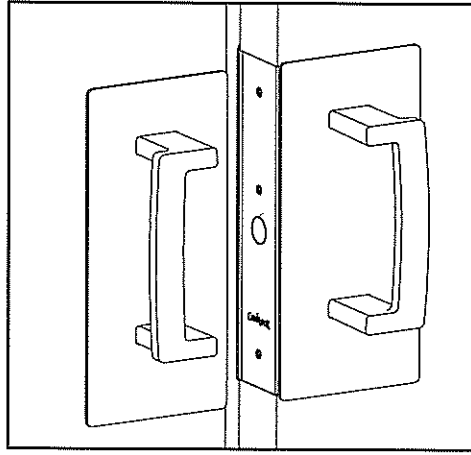

### Before you Start:

- These handles have been manufactured to specifications which **cannot** be altered by the installer. These include:
  - Handle type:** the CL400 ADA handle is available in *Passage*, *Privacy* and *Bi-Parting* versions. You have purchased the **Bi-Parting Passage (Magnetic Latching)** version.
  - Configuration:** the Passage handle configurations include; *Passage Magnetic Latching* and *Passage Non Latching*.
  - Door thickness range:** There are four different door thickness ranges: 34-40mm, 40-46mm, 46-52mm and 52-58mm (1-3/8" to 1-9/16", 1-5/8" to 1-3/4", 1-13/16" to 2" and 2-1/16" to 2-1/4"). Handles for thicker doors are available on request.  
Refer to the information printed on the *Side Handle* and *Chassis* boxes to ensure you have purchased the handles with the correct specifications for your situation. **If the specifications are incorrect you will need to exchange the handles.**
- Component drawings have been provided. Please familiarise yourself with the components and check the package to ensure nothing is missing.
- To ensure the handles latch accurately, it is essential that both doors are adjusted for height and are parallel with each other when closed **before** installing the handles.
- The CL400 is a metric handle. **Accurate measurements are shown in millimetres. Conversions to inches are approximate.**
- NZS4121:2001:** To comply with NZS4121:2001 the centre of the handles should be positioned between 900mm and 1200mm (1000mm optimal) above finished floor level. There must be a minimum clear walk through of 760mm (Aust. 850mm). There must be a 45mm clear space from edge of pull handle to door jamb when the doors are fully open. Consult local standards for guidelines relating to the specific project.  
**USA ADA (American Disabilities Act) Guidelines:** Handle should be positioned between 34 - 48" above finished floor level. Allow a minimum of four inches for the protrusion of the door in the open position. This can be achieved by using track stops or blocking in the back of the pocket. Consult local standards for guidelines relating to the specific project.

### Door Preparation

- Mark a line on the face of the doors where the centre of the handles are to be positioned. Align the centre line on the *door cut out template* with the centre line on the door. Follow the instructions on the template. Repeat cut out for both doors.

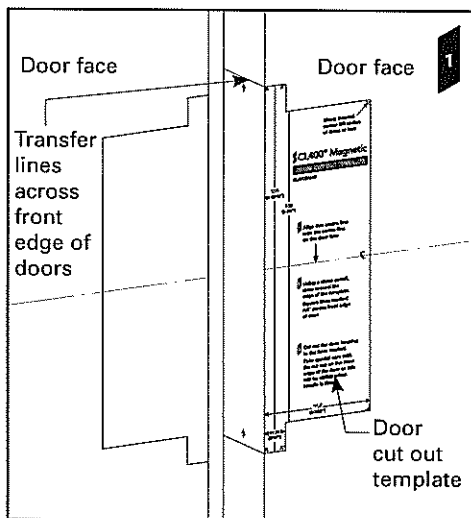

- Mark two holes in the centre of the door thickness in the positions shown. Using these marks, drill two 2.5mm (3/32") diameter holes to a depth of 35mm (1-3/8"). Repeat holes for both doors.

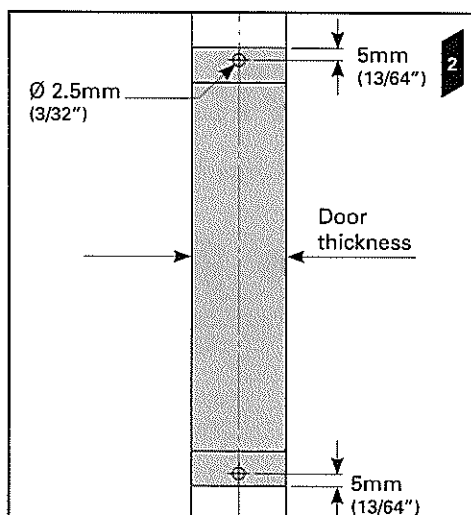

### Fitting the Bi-Parting Mate

- The Bi-Parting chassis contains a strong magnet. **Read the warning on page 2 before continuing.** Remove the *Bi-Parting chassis* from its packaging. Remove the *face plate screw* and *face plate* from the chassis. Align the chassis with the centre of the door thickness. Screw the chassis to the door (using the two *chassis mounting screws*) through the slotted holes at the top and bottom of the chassis. **DO NOT** fully tighten the screws. Realign the chassis with the centre of the door thickness. When happy with the chassis position, fully tighten the screws.

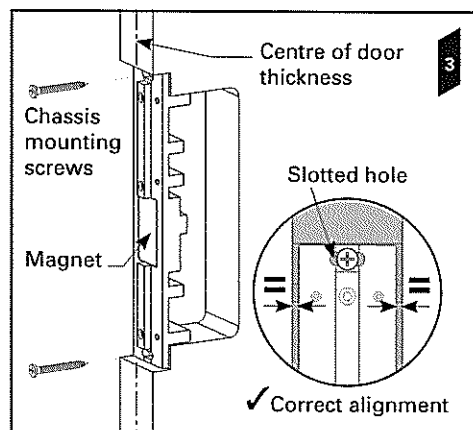

- Fit the 6x *side handle to chassis screws*. Leave a 3mm gap (1/8") between the underside of the screw head and the chassis.

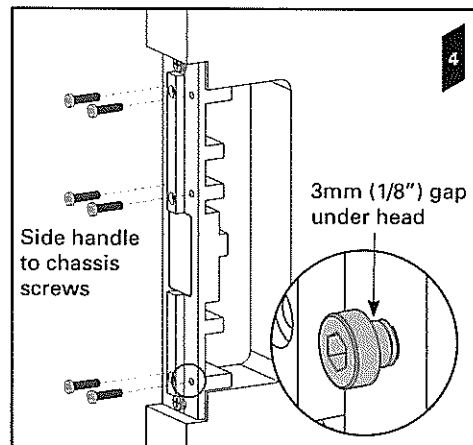

### Component Drawings - Bi-Parting Mate Offset handle option shown.

#### Bi-Parting Side Handle Box

- a Bi-Parting Side Handle (Left)
- b Bi-Parting Side Handle (Right)

#### Bi-Parting Chassis Box

- c Bi-Parting Face Plate
- d Bi-Parting Chassis
- e Magnet
- f Chassis Mounting Screws (2)
- g Side Handle to Chassis Screws (6)
- h Face Plate Screws (3)
- i Handle Joining Screws (2)

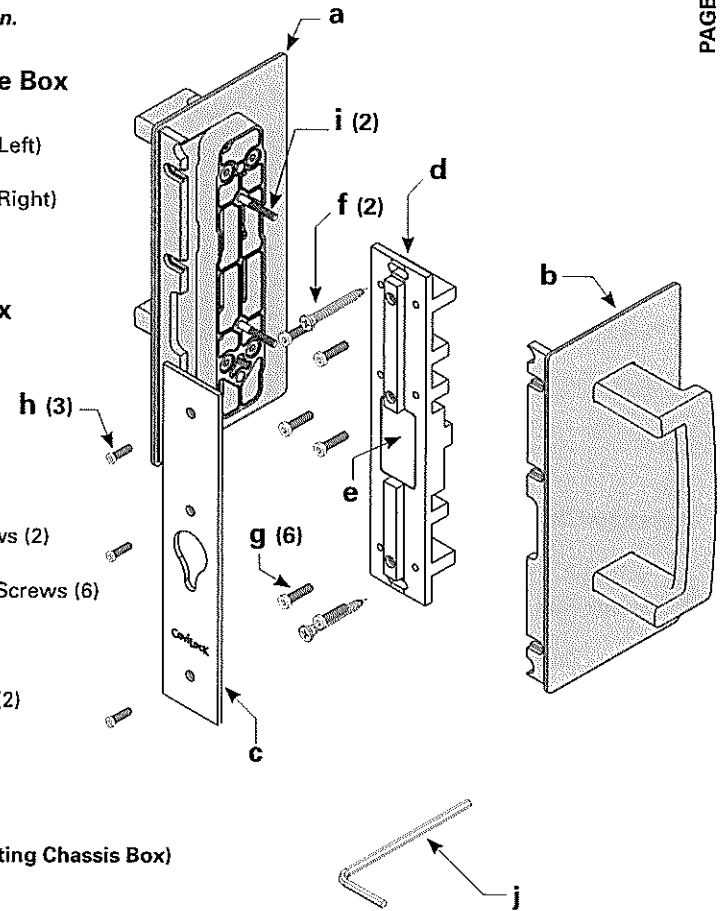

#### Tools (contained in Bi-Parting Chassis Box)

- j CL400 Allen Key

**WARNING: THE BI-PARTING CHASSIS CONTAINS A STRONG MAGNET**

**IRON FILINGS** - Magnets will attract shavings from iron or ferrous metals which may be hard to remove. Keep magnets a safe distance away from these materials.

**DANGER FOR CHILDREN** - Magnets may cause serious injury if swallowed. Keep out of reach of children.

**CRUSHING, BLISTERS AND CUTS** - Fingers may become caught between magnets resulting in crushing, blisters or cuts.

**BREAKING OR CHIPPING** - It is possible that magnets could chip or shatter on contact with other hard materials, resulting in chips flying off at high speed into someone's eye. Chips can also be very sharp - treat them as you would broken glass.

**MAGNETICALLY SENSITIVE ITEMS** - Keep a safe distance between the magnet and all objects that can be damaged by magnetism (e.g. mechanical watches, pacemakers, cell phones etc.).

**DISPOSAL** - Magnets should be disposed of carefully and in accordance with your local regulations.

### 3

### Fitting the Bi-Parting Mate

- Select the *Bi-Parting side handle* that has no visible fasteners (see diagram 5). Fit it to the chassis by sliding the front flange of the handle under the heads of the 3x side handle to chassis screws. Tighten the screws.

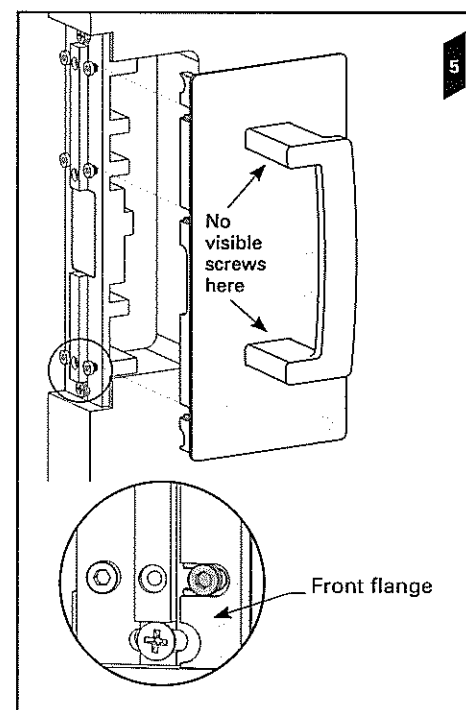

- Fit the remaining Bi-Parting side handle to the chassis and tighten the 3x side handle to chassis screws.

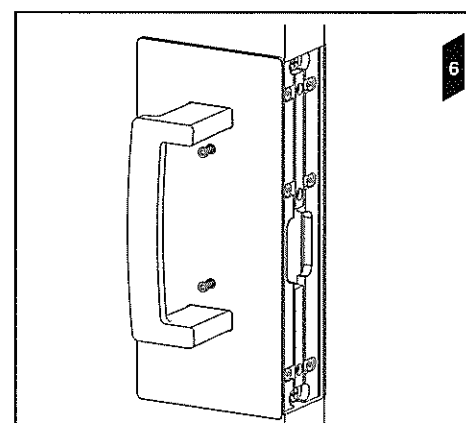

- Use the ball end of the *CL400 Allen key* to tighten the 2x handle joining screws. Use the other end of the Allen key to firmly tighten the screws.

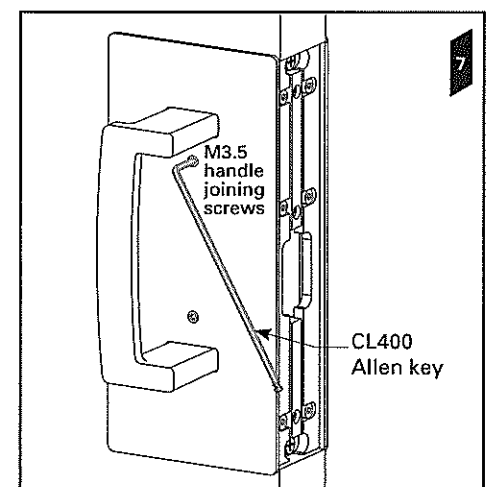

- Fit the *Bi-Parting face plate* to the chassis using the 3x *face plate screws*.

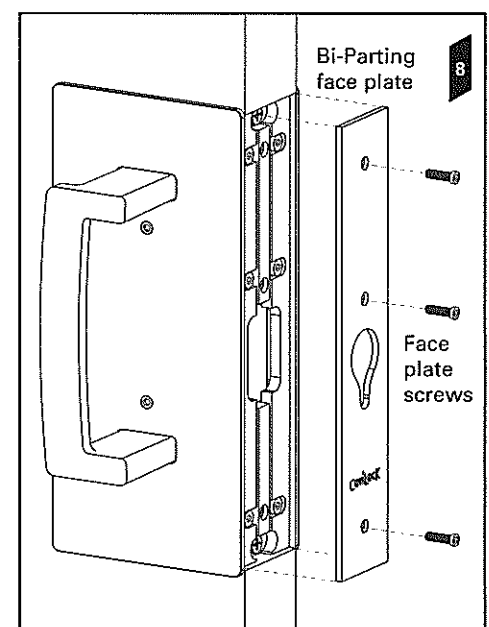

Go to page 5 (overleaf) →

**Component Drawings - Passage Handle**  
*Offset handle option shown.*

**Passage Side Handle Box**

- j** Passage Side Handle (Left)
- k** Passage Side Handle (Right)

**Passage Chassis Box**

- i** Passage Face Plate
- m** Passage Chassis
- n** Plunger
- o** Plunger Nut
- p** Spring Reservoirs (2)
- q** Chassis Mounting Screws (2)
- r** Side Handle to Chassis Screws (6)
- s** Face Plate Screws (3)
- t** Handle Joining Screws (2)

**Tools (contained in Passage Chassis Box)**

- u** Plunger Adjustment Spanners (2)

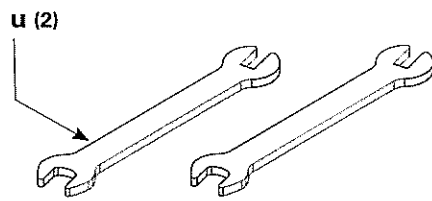
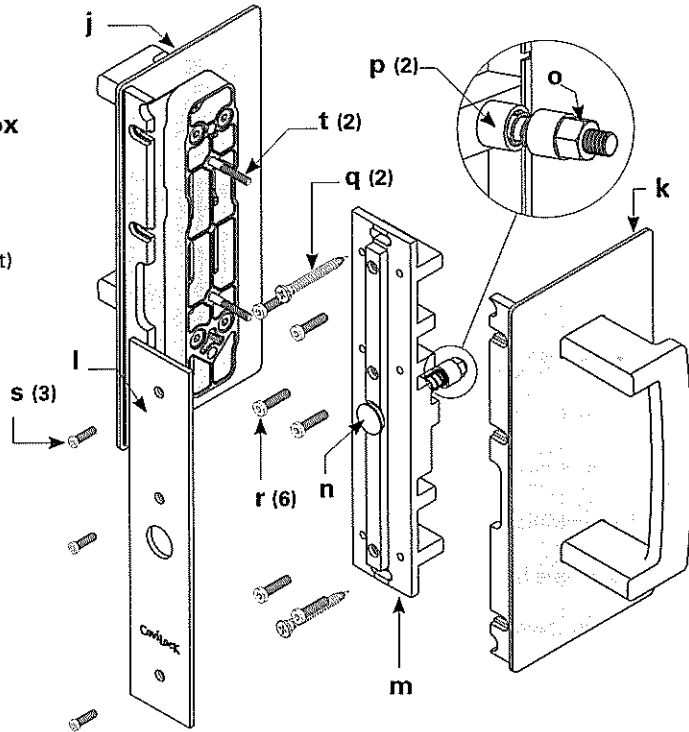

**Adjusting the Plunger**

**12.** Manually push the *plunger* in the passage chassis forward until there is no gap between *spring reservoir one* (SR1) and *spring reservoir two* (SR2).

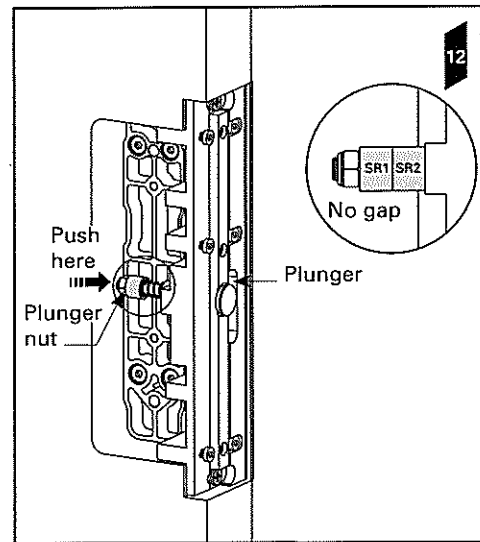

**13.** Two identical spanners have been supplied. Restrain the *plunger nut* using the **large** end of one of the supplied *spanners*. Place the **small** end of the second spanner across the flats under the head of the plunger. Keep the spanner restraining the plunger nut **stationary** while turning the second spanner **clockwise**.

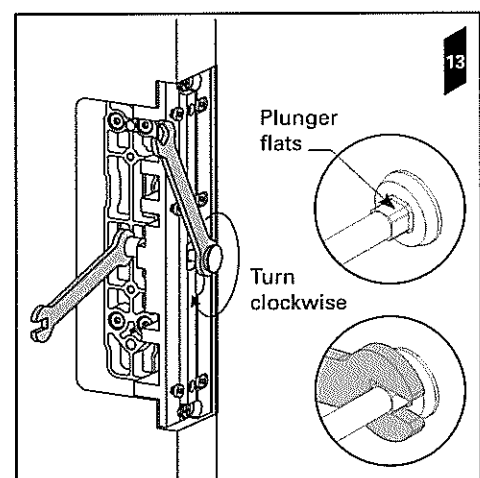

**14.** Continue to turn the spanner until there is no longer a gap between the spanner and the chassis.

Now turn the spanner **anti clockwise** half a turn.

The plunger should now be adjusted correctly. Slide the doors closed and check that they latch. Adjust if necessary.

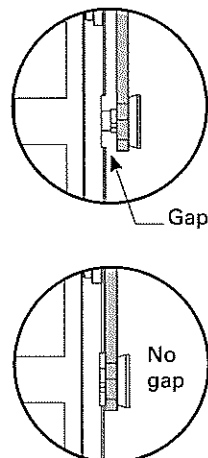
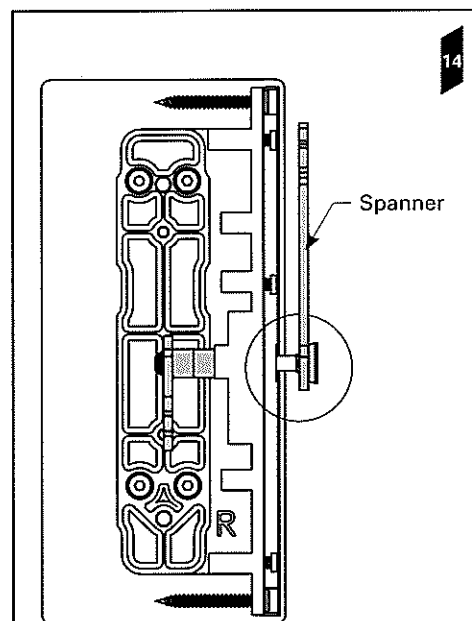

**Fitting the Passage Handle**

**9.** Remove the *passage chassis* from its packaging. Remove the *face plate screw* and *face plate* from the chassis.

Align the chassis with the centre of the door thickness. Screw the chassis to the door (using the two *chassis mounting screws*) through the slotted holes at the top and bottom of the chassis. **DO NOT** fully tighten the screws.

Realign the chassis with the centre of the door thickness. When happy with the chassis position, fully tighten the screws.

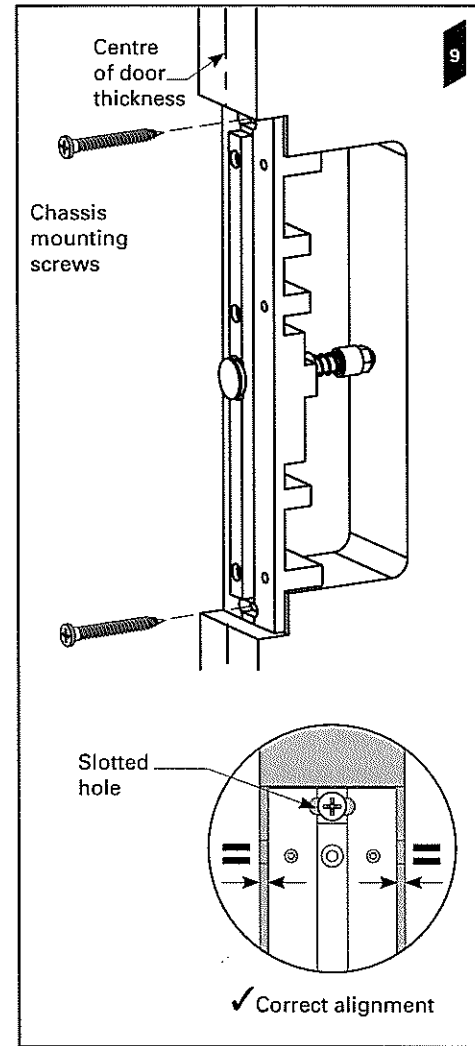

**10.** Fit the 6x *side handle* to chassis screws. Leave a 3mm gap (1/8") between the underside of the screw head and the chassis.

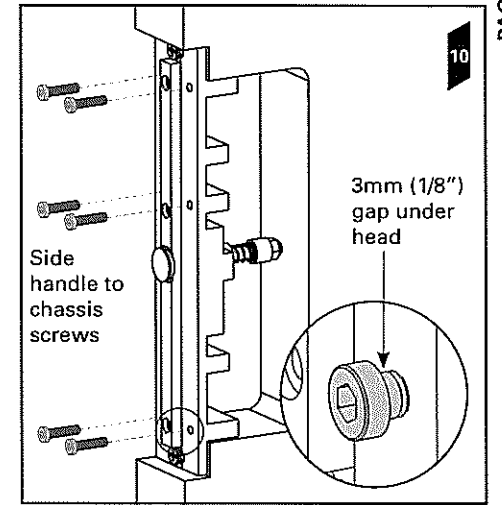

**11.** Fit the *passage side handle* (with no visible fasteners) to the chassis by sliding the front flange of the handle under the heads of the 3x *side handle to chassis screws*.

Tighten the screws.

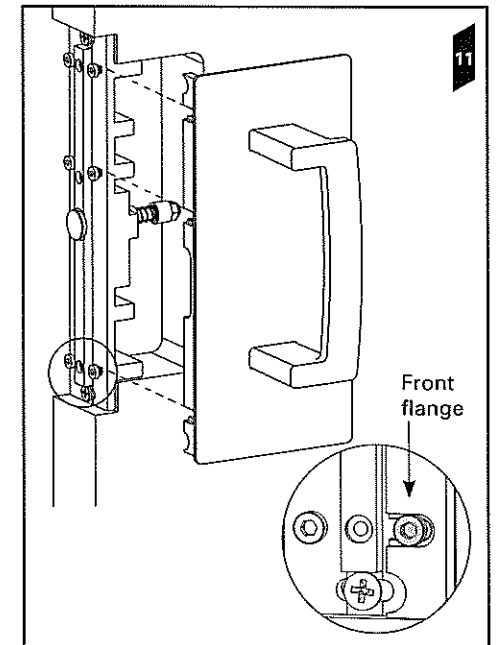

**Fitting the Remaining Side Handle**

**15.** Fit the remaining passage side handle (with visible M3.5 screws fitted) to the chassis (using the 3x *side handle to chassis screws*) by sliding the front flange of the handle under the heads of the three screws. Tighten the screws.

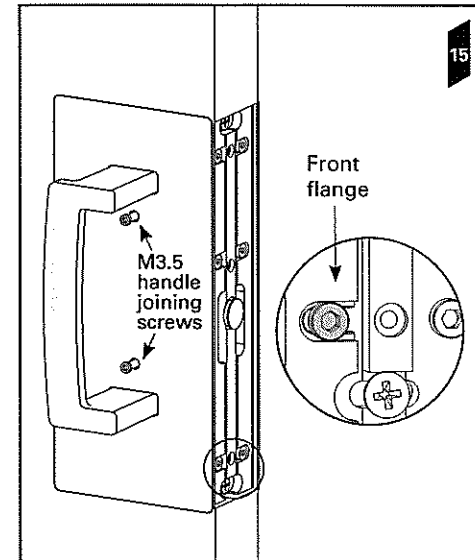

**16.** Use the ball end of the *CL400 Allen key* to fasten the 2x *M3.5 screws* as tight as possible. Use the other end of the Allen key to fully tighten the screws. **It is important that they are tight.**

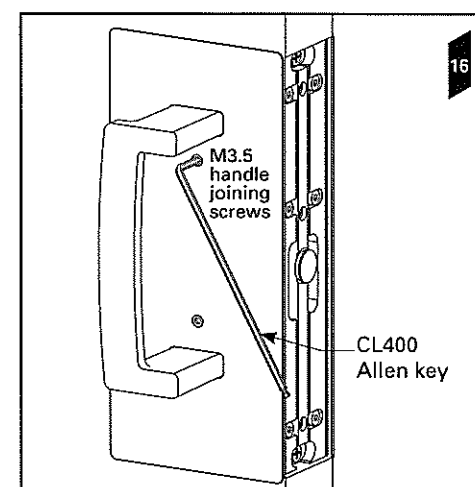

**Fitting the Face Plate**

**17.** Fit the *passage face plate* to the chassis using the 3x *face plate screws*.

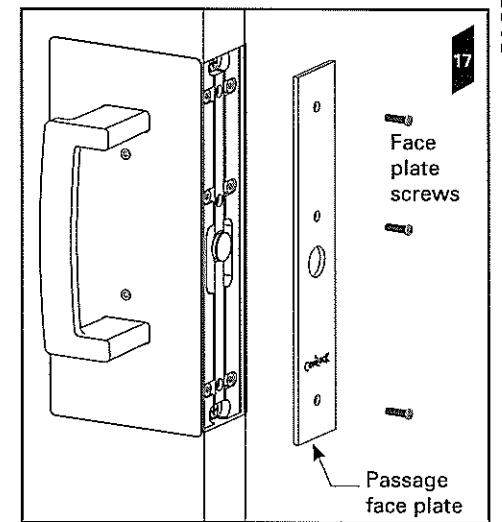

© Cavity Sliders Limited. CAVILOCK® CL400® MAGNETIC (O.D. 2013) ADA PASSAGE BIPARTING INSTRUCTIONS. 61231/ZG00109 - 11.2019  
All copyright and other property in this document is reserved by Cavity Sliders Limited. Details and specifications are subject to change without notice. Whilst all care is taken to ensure the accuracy of all information, no responsibility will be accepted for any errors or omissions. © CS FOR DOORS, CS CAVITY SLIDERS and CAVILOCK are Registered Trademarks. Patents pending.

**CaviLock®**  
Handles & Locks for Sliding Doors

**FOR DOORS** CavitySliders



Cavity Sliders Limited  
Auckland Head Office  
5-7 Rakino Way  
Mt Wellington  
Auckland, NZ

www.csfordoors.co.nz  
www.cavitysliders.com.au  
www.cavitysliders.com

T +64 9 276 0800  
F +64 9 276 2525  
info@csfordoors.co.nz