

# CS AutoCav 3 1/2" Commercial

Single Cavity Slider Pocket Frame To Suit:  
5/8" (16mm) Linings (Dry Wall) & Flat Jamb

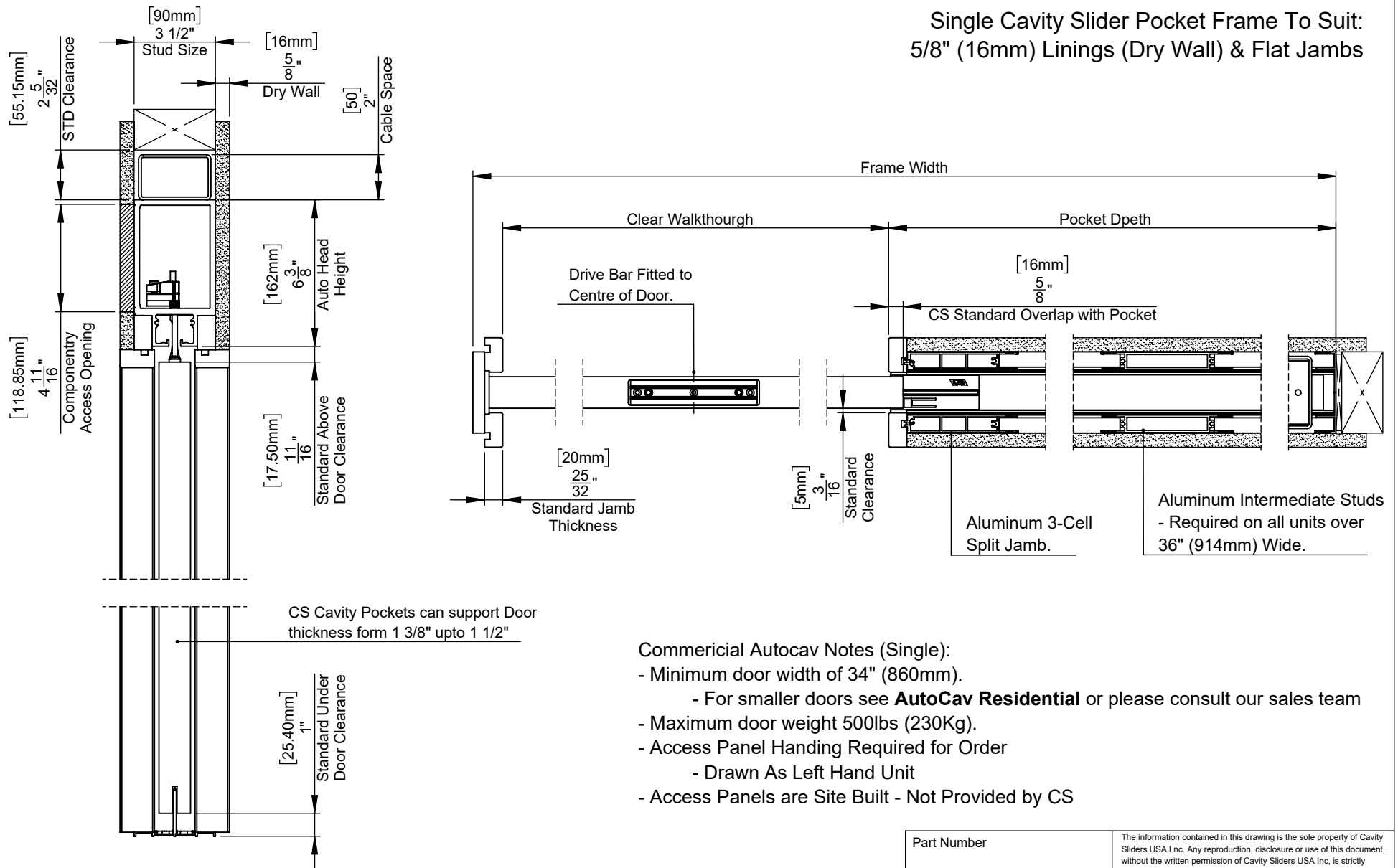

Floor clearance adjustable to give 7/8" - 1 3/16" (22 - 30mm) gap. If less gap required a taller door or smaller cavity slider pocket frame must be specified

### Commercial Autocav Notes (Single):

- Minimum door width of 34" (860mm).
  - For smaller doors see **AutoCav Residential** or please consult our sales team
- Maximum door weight 500lbs (230Kg).
- Access Panel Handing Required for Order
  - Drawn As Left Hand Unit
- Access Panels are Site Built - Not Provided by CS

Part Number		The information contained in this drawing is the sole property of Cavity Sliders USA Inc. Any reproduction, disclosure or use of this document, without the written permission of Cavity Sliders USA Inc, is strictly prohibited.   Quality Sliding Door Hardware 548 Finney Ct, Gardena, CA 90248 Phone +1 (888) 466 0030 Fax +1 (310) 769 5824 www.cavitysliders.com
Units		
Measurements in mm & Inches		
Scale	Sheet	
Not to Scale	1 of 3	
Date	Rev.	
7/12/2020	-01	

**CS AutoCav 3 1/2" Commercial**  
 Single Cavity Slider Pocket Frame To Suit: 5/8"  
 (16mm) Linings (Dry Wall) & Flat Jamb

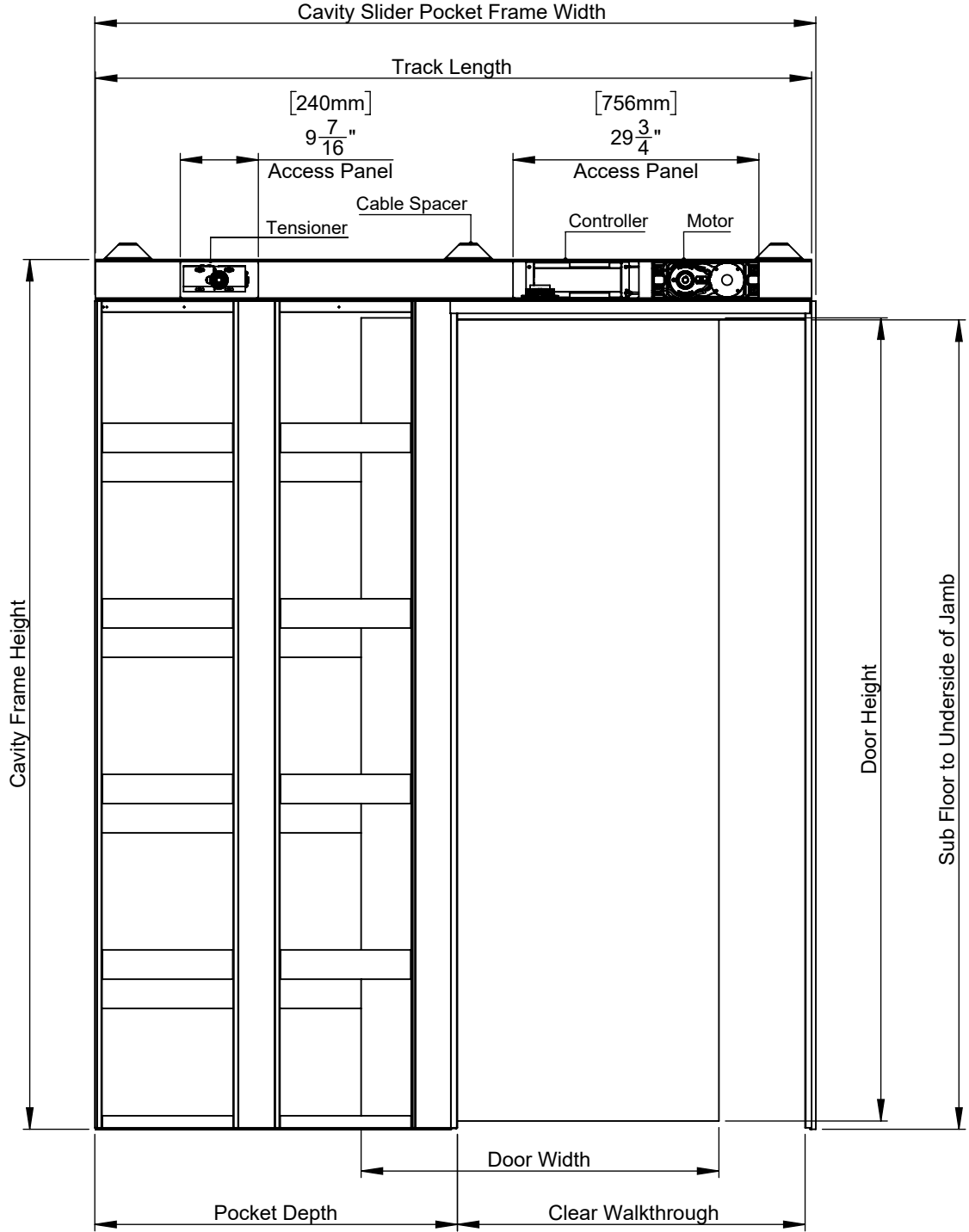

Part Number		<small>The information contained in this drawing is the sole property of Cavity Sliders USA Inc. Any reproduction, disclosure or use of this document, without the written permission of Cavity Sliders USA Inc, is strictly prohibited.</small>  Quality Sliding Door Hardware 548 Finney Ct, Gardena, CA 90248 Phone +1 (888) 466 0030 Fax +1 (310) 769 5824 www.cavitysliders.com
Units Measurements in mm & Inches		
Scale Not to Scale	Sheet 2 of 3	
Date 7/12/2020	Rev. -01	

# CS AutoCav 3 1/2" Commercial

Bi-Parting Cavity Slider Pocket Frame To Suit:  
5/8" (16mm) Linings (Dry Wall) & Flat Jamb

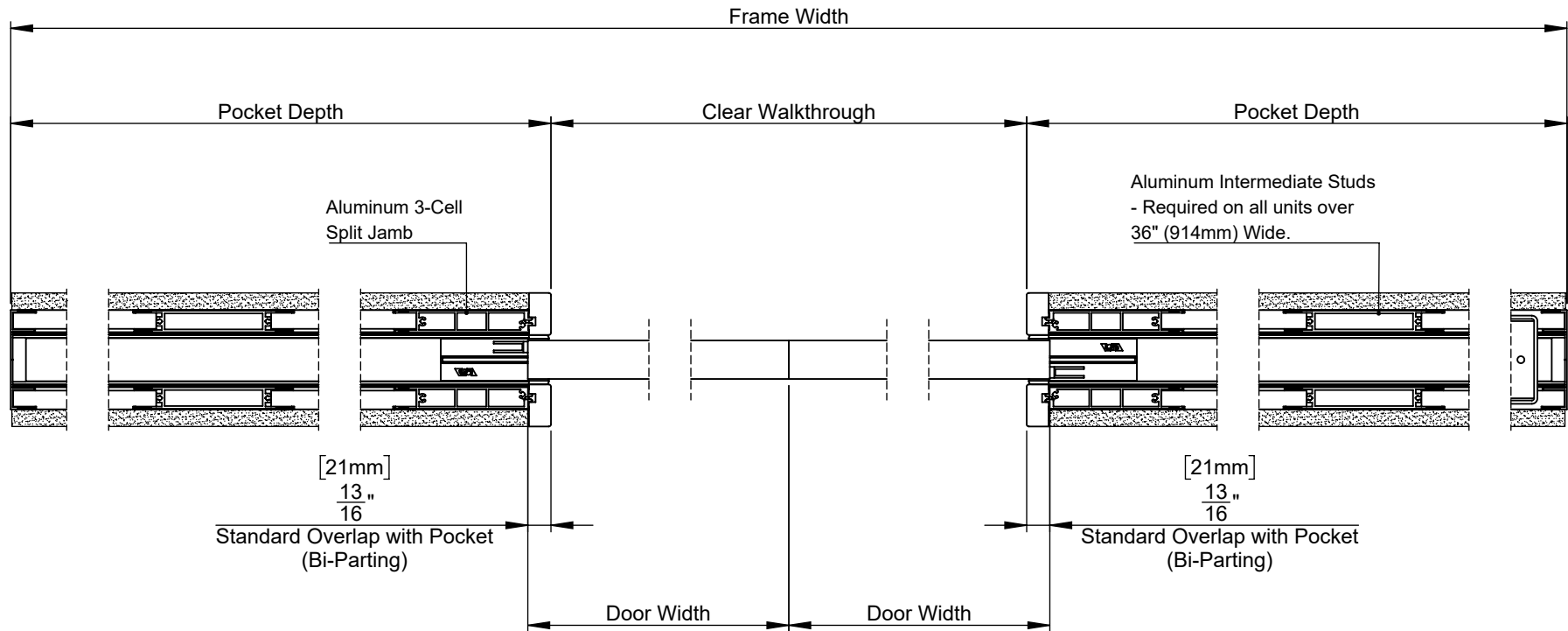

### Commercial Autocav Notes (Bi-Parting):

- Minimum door width of 34" (860mm).
  - For smaller doors see **AutoCav Residential** or please consult our sales team
- Maximum door weight 285lbs per Door (130Kg).
  - Total System Weight 570lbs (260Kg)
  - For heavier doors please consult our sales team
- Access Panels are Site Built - Not Provided by CS
  - Hanging not required for Bi-parting Units

Part Number		The information contained in this drawing is the sole property of Cavity Sliders USA Inc. Any reproduction, disclosure or use of this document, without the written permission of Cavity Sliders USA Inc, is strictly prohibited.   Quality Sliding Door Hardware 548 Finney Ct, Gardena, CA 90248 Phone +1 (888) 466 0030 Fax +1 (310) 769 5824 www.cavitysliders.com
Units Measurements in mm & Inches		
Scale Not to Scale	Sheet 3 of 3	
Date 7/12/2020	Rev. -01	